

Data Sheet

FED

Thermostatic Controller for Cooling & Heating Circuits

Application:



FED thermostatic controllers are used in hydronic applications where both a cooling and a heating circuit are regulated by one controller. The FED is available in two versions, FED-IF with integrated room air sensor, and FED-FF with a remote air sensor. Both the FED-IF and the FED-FF are low cost methods of controlling chilled ceilings, radiators, fan coils, and induction units. In situations requiring a faster response time, the FED FF's remote sensor can be placed directly in the air stream providing an option of mounting the dial directly on a cabinet.

Ordering Information:

Code No.	Operator	Sensor	Capillary Tube	Setting Range
013G5463	FED-IF	Integrated	12 + 36ft (4 + 11 m)	63 - 80 °F (17 - 27 °C)
013G5462	FED-FF	Remote	6 + 6 + 6 ft (2 + 2 + 2m)	

*The cooling adapter is recommended to be mounted to the RA-C series of valves, while the heating adapter can be mounted to either the RA2000 or RA-C series of valves.

Application:

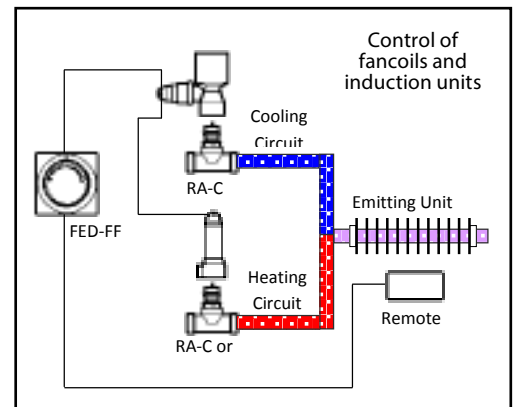
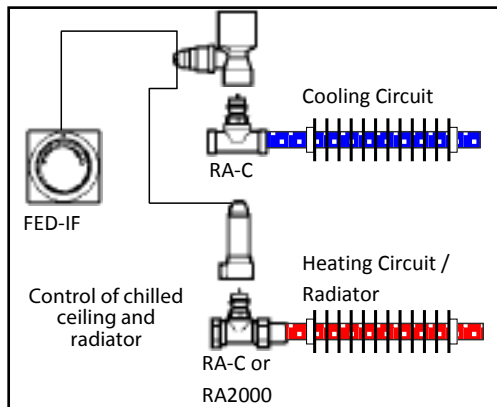

FED Sensor Design:

The FED sensor is equipped with a heating adapter and cooling adapter (reverse device). Both are connected via capillary tubes to the remote temperature adjuster (dial). The reverse device will open the valve in the cooling circuit as the temperature rises above the set point temperature. Similarly, the heating adapter will open the valve in the heating circuit when the temperature falls below the set point temperature. With the FED-FF model an additional capillary tube from the dial connects to a remote temperature sensor.

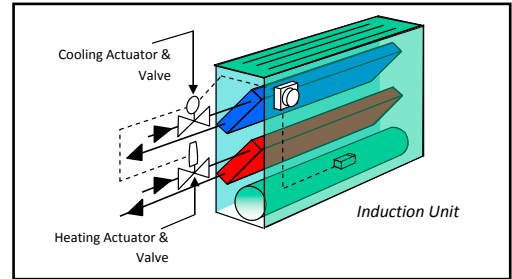

Serial Coupling

A unique ability with the FED thermostatic operator is the interchangeability of the cooling and heating adapters. Out of the box, the FED sensor is assembled with the cooling adapter closest to the dial and the heating adapter further away. Yet this order can easily be exchanged and the FED sensor will still control in the right sequence. The interchange of valve adapters expands the possibilities of the dial placement.

Temperature Limitation

Incorporated into the dial is the unique ability to limit the rotation of the dial providing minimum and maximum limitation of the temperature settings. To set this limitation the front cover of the dial is removed exposing the setting tabs.

Temperature Setting:

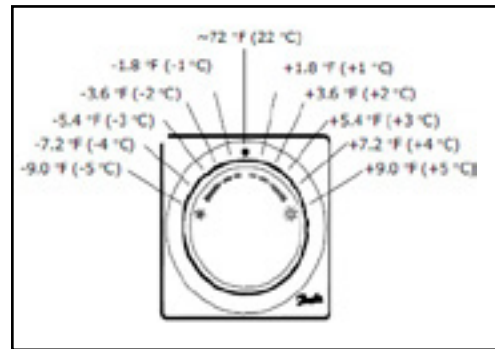

When the dial is set to the center as shown in the illustration above, the thermostatic operator will maintain a comfort temperature of around 72°F (22°C). By rotating the dial to the red or blue side, the comfort temperature will be shifted as a result. In the state where room temperature is satisfied, neither the cooling nor the heating circuit would be opened. If the temperature rises above the set point temperature, the reverse device will cause the valve

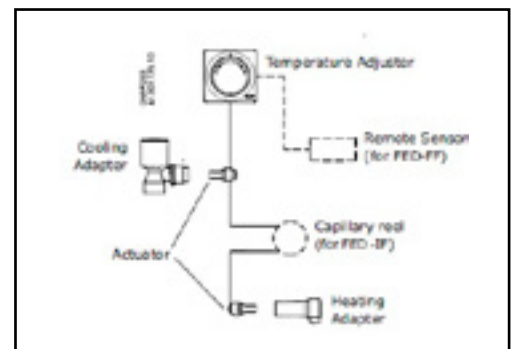

for the cooling circuit to open. Likewise, if the temperature falls below the set point the cooling circuit will close and the heating circuit valve will open.

Built into the cooling adapter is a neutral zone (also known as a dead band) to ensure that both the heating and cooling valves do not operate simultaneously. The neutral zone has a settable range of 0.9°-4.5° (0.5°-2.5°C), and can be adjusted depending on the

Temperature Setting (Cont.):

system design and requirements by rotating the knob located on the cooling adapter with a set of pliers. The knob when turned clockwise will increase the dead band and if turned counter-clockwise will decrease it. The factory setting of the neutral zone is marked on the knob recess.

Example - Setting the Dial

For this example the dial is turned clockwise to the blue side of the settings, lowering the set comfort temperature from 72°F (22°C) to approximately 66°F (19°C). Additionally the neutral zone (dead band) has been preset to 3°F. As a result, the set temperature of 66°F (19°C) plus the neutral zone of 3°F produces a range of 63-69°F where neither heating nor cooling occurs.

P-Band

A contributing factor to the ability of the FED's workable temperature range deals with the concept known as the proportional band or P-band. This concept applies differently than the neutral zone. The P-band correlates to the valve's ability to provide the appropriate amount of flow that meets the demand of the terminal unit (chilled ceilings, radiators, fan coils, or induction units). The proper flow can determine the controller's ability to maintain the set temperature. The shaded region seen in the figure below relates the ambient temperature and the required flow to bring the temperature back to the set temperature. When the temperature hits maximum as seen in the graph, the valve is fully open based upon its setting. In the adjustment of the valve's flow, as seen with the RA-C's flow pre-settings of 1-2-3 & N, the maximum flow of the terminal unit should be matched to the pre-setting capacities of the RA-C valve. In properly setting the valve refer to the RA-C capacity diagrams and consider a P-band based upon load requirements of 5.4°F (3°C) from the set temperature.

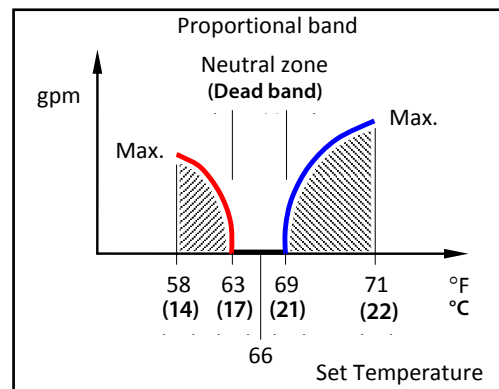
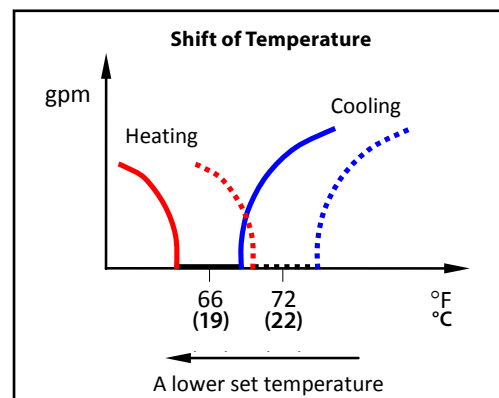
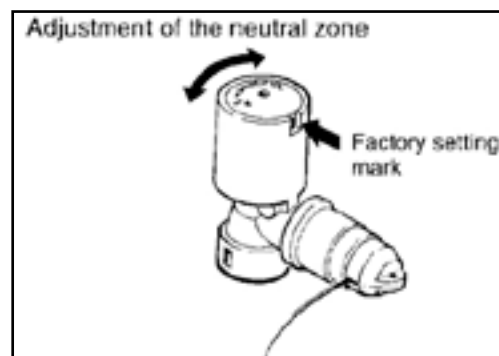

Design:

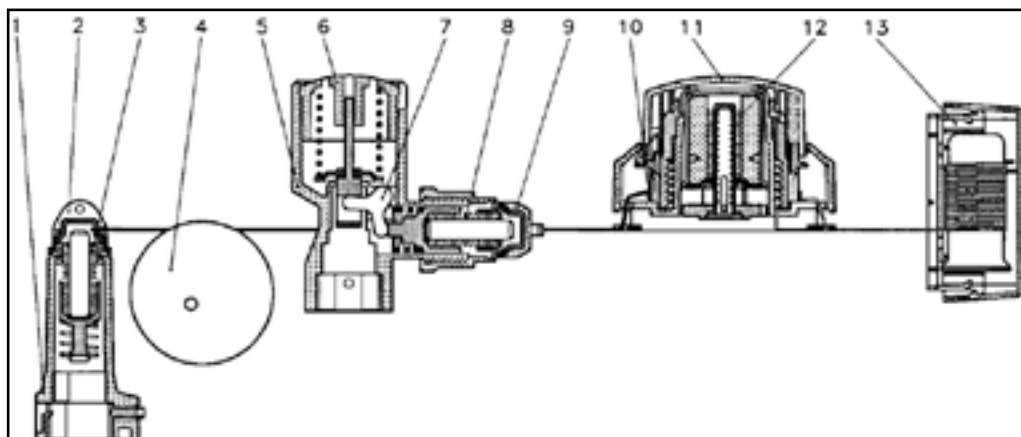

- | | | | |
|----|------------------------------|-----|---|
| 1. | Heat adapter | 8. | Adjustment bellow |
| 2. | Actuator | 9. | Actuator |
| 3. | Adjustment bellows | 10. | Capillary reel |
| 4. | Capillary reel (only FED-IF) | 11. | Remote temperature adjuster |
| 5. | Cooling adapter | 12. | Bellows |
| 6. | Neutral zone adjustment knob | 13. | Remote temperature sensor (only FED-FF) |
| 7. | Reverse device | | |

Dimensions:

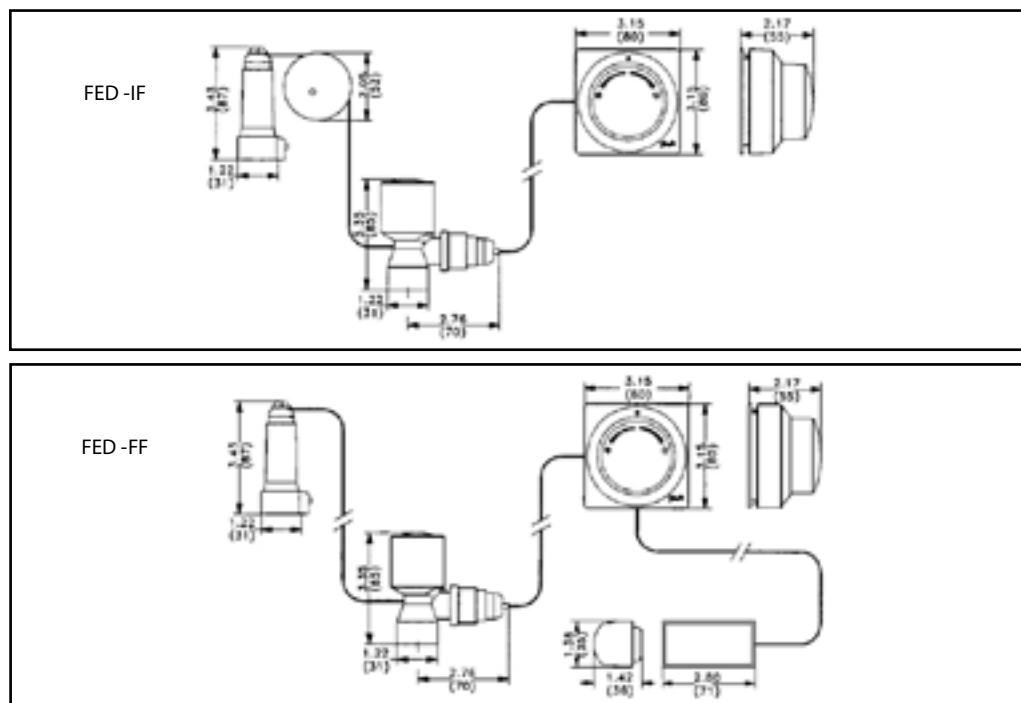

Danfoss can accept no responsibility for possible errors in printed materials and reserves the right to alter its products without notice. All trademarks in this material are property of the respective companies. Danfoss and Danfoss logotype are trademarks of Danfoss A/S. All rights reserved.



Danfoss Inc.
 Toronto, ON
 Toll Free: 866-375-HVAC (4822)
 Tel.: 905-285-2050, Fax: 905-285-2055
www.na.heating.danfoss.com

Danfoss Inc.
 Baltimore, MD
 Toll Free: 866-375-HVAC (4822)
 Tel.: 443-512-0266, Fax: 443-512-0270
www.na.heating.danfoss.com